



**WS-29**

## **DUAL CHANNEL WIRELESS BELTPACK**



### **USER MANUAL**

Issue March 2011 © ASL Intercom BV

**DESIGNED AND MANUFACTURED BY:**

ASL INTERCOM BV  
ZONNEBAAN 42  
3542 EG UTRECHT  
THE NETHERLANDS  
PHONE: +31 (0)30 2411901  
FAX: +31 (0)30 2667373  
WEB: [www.asl-inter.com](http://www.asl-inter.com)  
E-MAIL: [info@asl-inter.com](mailto:info@asl-inter.com)

## CONTENT OF THIS USER MANUAL

1.0	INTRODUCTION.....	3
2.0	UNPACKING.....	3
3.0	INSTALLATION.....	3
4.0	FRONT PANEL CONTROLS .....	4
5.0	SIDE PANEL TRIMMERS .....	4
6.0	REAR PANEL CONTROLS & CONNECTOR .....	5
7.0	INTERIOR .....	5
8.0	FREQUENCY BAND & ANTENNA'S .....	6
9.0	SETTING UP CONNECTIONS .....	6
10.0	COMMUNICATION MODES.....	9
11.0	WARRANTY .....	10
12.0	TECHNICAL SPECIFICATIONS.....	10

## 1.0 INTRODUCTION

An ASL wireless intercom system may consist of 1-channel belt packs (WS-19), 2-channel belt packs (WS-29), 2-channel base stations (WS-200) and 4-channel base stations (WS-400).

It is a stand-alone system but may also be the wireless extension of a wired intercom system. The base stations have a built-in interface to 4-wire and to 2-wire (party line) intercom.

The WS-29 is a dual channel wireless belt pack, housed in a strong aluminum case. The unit has a Volume (listen level) control, a MIX control, and – for each channel - a TALK and a CALL button with LED indicators

The WS-29 is called “dual channel” but has only one TX/RX (send/receive) module. The MIX control mixes the audio of channel A and channel B as sent to the headset. This mixing takes place in the base station.

ASL uses the 2.4 GHz frequency band for the communication between its wireless belt packs and base stations.

A maximum of 8 full duplex wireless connections can be made, simultaneously operated without any interference.

The unique ASL Call system provides both a flashing red LED and a very distinctive and characteristic sound signal. A momentary push makes the red LED flash, whilst holding the button for two seconds it will activate the CALL sound signal. The volume of the sound signal (buzzer) can be adjusted at the side panel.

## 2.0 UNPACKING

The shipping carton contains the parts listed below:

- The WS-29
- User manual
- 6x NiMh rechargeable batteries
- Charger

If any are missing, contact your dealer.

ASL has taken great care to ensure this product reaches you in flawless condition.

After unpacking the unit, please inspect for any physical damage. Retain the shipping carton and relevant packing materials in case the unit needs to be returned.

If any damage has occurred, please notify your dealer immediately so that a written claim can be initiated. Please also refer to the warranty section of this manual.

## 3.0 INSTALLATION

The supplied rechargeable batteries are empty, insert them in the belt pack and charge them before use. For charging instructions see section 6.0 / #13

The WS-29 is used in an existing or new wireless intercom system. The necessary DC voltages are derived from the internal batteries (see section 7.0 / #16).

Adjust the channel select switch to match the selected channel on the installed base station (a WS-200 or a WS-400). After switching on the WS-29 with the power switch at the rear panel, the unit should have contact with the base station. To check this, push a CALL or TALK button and the green LED of the corresponding TX/RX module in the base station should be lit.

See also section 9.0 (Setting up Connections) and section 10.0 (Communication Modes)

## 4.0 FRONT PANEL CONTROLS

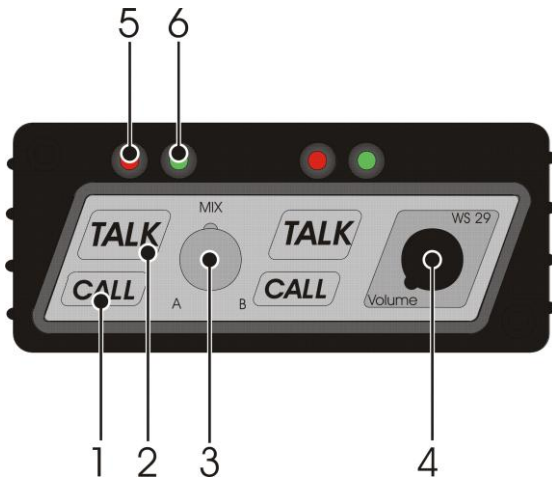

### 1 CALL buttons

These push buttons (one for each channel) activate the call system. A momentary push sends a call signal to all wired/ wireless intercom stations connected to this beltpack (see section 9) and the Call LED starts flashing. Pushing the button for 2 seconds activates the CALL buzzer.

After the CALL button is released the call LED continues to flash for a further 2 seconds. To send or receive a CALL signal, the beltpack must be in reach of the base station.

### 2 TALK buttons

These push buttons (one for each channel) activate the headset microphone; the green Talk LED indicates the microphone is switched on. One talks to the wired and wireless intercom stations which are connected to this beltpack (see section 9).

For the TALK button to function, the unit must stay in reach of the base station. If not, the TALK button switches off (the Talk LED extinguishes). As soon as the beltpack is in reach of the base station again, the Talk functions are restored automatically.

### 3 MIX control knob

To mix the audio signal of channel A and channel B as sent to the headset. This mixing takes place in the base station. See also the WS-200 manual, section 7 or the WS-400 manual, section 7.

### 4 VOLUME control knob

To adjust the listen level for the headset.

### 5 Call LED (red)

### 6 Talk LED (green)

## 5.0 SIDE PANEL TRIMMERS

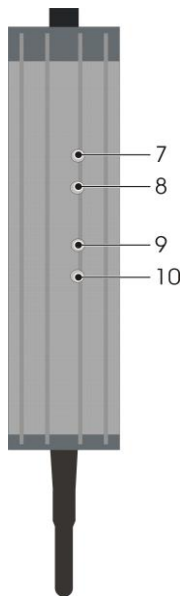

### 7 TONE VOLUME trimmer

This trimmer adjusts the level of the tones which the WS-19 generates in case of a low battery warning and at start up.

### 8 OWN VOICE trimmer

This trimmer adjusts the level of your own voice as you hear it in your headset. Adjusting this signal does not affect the level of your voice as heard by other wireless or wired intercom stations (see section 9)

### 9 BUZZER VOLUME trimmer

This trimmer adjusts the volume of the internal buzzer. The buzzer is activated by pushing a CALL button of the WS-29, or the CALL button of any other wired or wireless intercom station connected to this beltpack (see section 9) for longer than 2 seconds.

### 10 MIC GAIN trimmer

With this trimmer, the mic gain can be adjusted. To increase mic gain turn trimmer clockwise. To decrease mic gain turn trimmer counter-clockwise

## 6.0 REAR PANEL CONTROLS & CONNECTOR

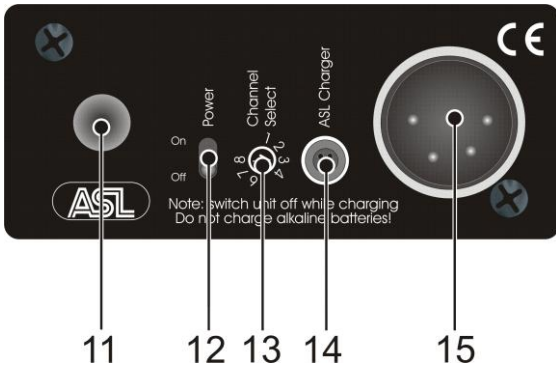

### 11 Antenna

This small antenna is very flexible and non-removable. For optimum performance keep the antenna clear from obstacles.

### 12 POWER on/off switch

With this switch the battery power of the WS-29 is switched on and off.

### 13 CHANNEL SELECT switch

With this switch the TX/RX channel (see section 8) is selected on which the beltpack communicates with the base station. There is a choice out of 8 TX/RX channels. The selected TX/RX channel must match the selected TX/RX channel at one of the TX/RX modules in the base station.

### 14 ASL CHARGER connector

To this connector the ASL charger unit is connected. On the charger unit two LED's indicate the charging process. The red LED is lit during charging, the green LED is lit when the batteries are full.

- **Before starting the charging process, make sure that the beltpack is switched off (see #12) and check whether the batteries inside the beltpack are indeed of the rechargeable NiMh type. Trying to charge non-rechargeable batteries causes leakage of these batteries, resulting in serious and in most cases not repairable damage to the electronics of the beltpack.**
- **Use only the by ASL supplied battery charger. Never try to use any other adapter or charger unit.**

### 15 HEADSET connector

To this XLR-4 connector a headset can be connected. The headset can must have an impedance of minimum 200 ohms. If there 2 cans in parallel, each can must have an impedance of minimum 400 ohms.

The headset mic may be dynamic or electret.

## 7.0 INTERIOR

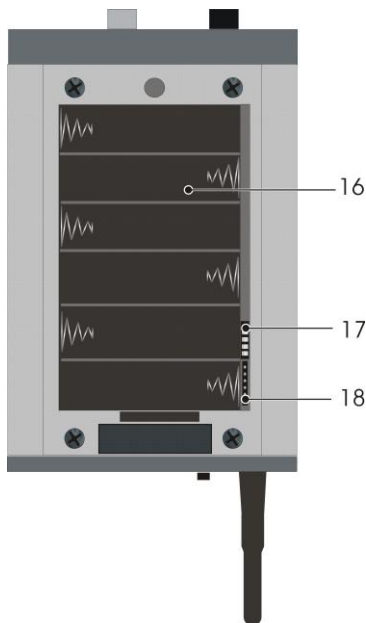

### 18 Service connector

For factory service only.

### 16 Battery Compartment

This compartment holds 6 penlight batteries of the AA type. The supplied NiMH batteries are to be preferred for maximum duration.

The WS 29 uses a high discharge current which the batteries need to sustain over their lifespan. Batteries which only supply a high current for a short time will be exhausted very quickly. When the batteries reach the end of their capacity, the beltpack gives a warning signal (4 tones). The interval of the tones shorten when the batteries wear out.

### 17 Dipswitch, to set function:

- A: Talk function only momentary
- B: Talk function disabled
- C: Buzzer function disabled
- D: Battery save mode  
(transmit power decreases)

To turn on a switch, slide towards side panel.

## 8.0 FREQUENCY BAND & ANTENNA'S

### 8.1 Frequencies

ASL's wireless intercom uses the 2.4 GHz band, which is freely available for WLAN (Wireless Local Area Networks).

The ASL system divides the available bandwidth into 16 overlapping sections, 8 of them being used as upload frequency (from the belt-pack to the base station) and the other 8 being used as download frequency (from the base station to the belt-pack).

With the channel select switches on both base stations and wireless belt-packs one actually selects an upload/download pair, **called a TX/RX channel**.

Each TX/RX channel serves one dedicated wireless connection between base stations and wireless belt-packs (in fact between the TX/RX modules in those units).

When using the ASL wireless system, the following should be taken into account:

- The 2.4 GHz frequency is known to have difficulty in penetrating concrete walls, steel walls and other obstructions. Behind obstructions like these an "HF shadow" may occur where no communication is possible.

- The antenna's of a base station should have as much as possible a "line of sight" to the antenna's of the belt-pack(s). All objects within that path make the connection less reliable. Due to reflections of the HF signal, one might experience a dropout on a specific spot in a building; moving a belt-pack only a few inches can be enough to solve the problem.
- Because of the use of the WLAN frequencies, ASL's wireless units might experience interference from units like mobile telephones with bluetooth and computers with bluetooth or WLAN cards. Try to change TX/RX channels if you experience problems with these.

### 8.2 Antenna Wiring (Base Stations)

If the antennas of a base station are not supposed to be directly connected to its front panel, a cable between base station and antenna is needed (base stations are equipped with SMA connectors - female at the base station and male at the antenna). The 2.4GHz frequency experiences a big loss in any cable, e.g. a RG58 cable has a loss of 1 dB per meter. So make sure that your cable (50 ohms) is suited for 2.4 GHz and that the cable is as short as possible. Make the cables in lengths of a multiple of 12, e.g. lengths of 24cm, 48cm, 120cm, 240cm etc.

## 9.0 SETTING UP CONNECTIONS

### 9.1 ASL WIRELESS AS A STAND ALONE SYSTEM

#### 9.1.1 Base Station Settings

- Give each TX/RX module in the base station its own TX/RX channel by rotating the 'Channel select' switch. Try to avoid TX/RX channels to be physically next to each other, e.g. when two WS-400's are in your wireless system, try to set them in this order: TX/RX channels 2, 4, 6, 8, 1, 3, 5, 7. If one uses a WS-200 with only two belt-packs, use TX/RX channels 1 and 6
- Make sure the interface mode switch at the rear of the base station is set to "PARTY LINE". The internal party line is now linking the on board TX/RX modules to each other.
- Turn down the side tone trimmers at the TX/RX modules (counter clockwise)

## 9.1.2 Wireless Beltpack Settings

- d. With the Channel Select switch at the rear of the beltpack, select the TX/RX channel according to the WS-200 or WS 400 setting.
- e. Connect a headset to the beltpack and insert fully charged batteries. When the beltpack is switched on, a single short tone should be heard and both LED's on the front panel of the unit flash for half a second. This indicates that the beltpack is functioning properly.
- f. When one pushes the CALL or the TALK button, the LED's on the front panel are lit and the green LED of corresponding TX/RX module in the base station is lit. It proves the beltpack has connection with the base station.
- g. Turn down the OWN VOICE Volume trimmer at the side panel of the beltpack (counter-clockwise)
- h. Set the volume control of the beltpack at approximately 50%
- i. Push the TALK button on the beltpack, talk into the microphone and listen to your own voice (you might hear a small delay in the signal)
- j. Adjust the side tone trimmer at the referring TX/RX module in the base station so that the level of your own voice is as low as possible
- k. Adjust the OWN VOICE trimmer on the beltpack so that the level of your own voice is to your liking.

## 9.2. ASL WIRELESS CONNECTED TO A 4-WIRE INTERCOM SYSTEM

### 9.2.1 Base Station Settings

- a. Give each TX/RX module in the base station its own TX/RX channel by rotating the 'Channel select' switch. Try to avoid TX/RX channels to be physically next to each other, e.g. when two WS-400's are in your wireless system, try to set them in this order: TX/RX channels 2, 4, 6, 8, 1, 3, 5, 7. If one uses a WS-200 with only two beltpacks, use TX/RX channels 1 and 6
- b. Make sure the interface mode switch at the rear of the base station is set to "4-WIRE"
- c. Connect the 4-wire intercom system via the XLR-3 connectors at the rear panel of the base station. Each XLR-3 male connector (signal out) and female connector (signal in) connects each TX/RX module to an input/output of the a 4-wire intercom system. The internal party line is now disconnected.

### 9.2.2 Wireless Beltpack Settings

- d. With the Channel Select switch at the rear of the beltpack, select the TX/RX channel according to the WS-200 or WS-400 setting.
- e. Connect a headset to the beltpack and insert fully charged batteries. When the beltpack is switched on, a single short tone should be heard and both LED's on the front panel of the unit flash for half a second. This indicates that the beltpack is functioning properly.
- f. When one pushes the CALL or TALK button, the LED's on the front panel are lit and the green LED of the corresponding TX/RX module in the base station is lit. It proves the beltpack has connection with the base station.
- g. Turn down the OWN VOICE Volume trimmer at the side panel of the beltpack (counter-clockwise)
- h. Push the TALK button on the beltpack, talk into the microphone and listen to your own voice
- i. Turn up the volume of your own voice by adjusting the OWN VOICE trimmer to a level that you like

### 9.3. ASL WIRELESS CONNECTED TO A PARTY LINE INTERCOM SYSTEM

#### 9.3.1 Base Station Settings

- a. Give each TX/RX module in the base station its own TX/RX channel by rotating the 'Channel select' switch.  
Try to avoid TX/RX channels to be physically next to each other, e.g. when two WS-400's are in your wireless system, try to set them in this order: TX/RX channels 2, 4, 6, 8, 1, 3, 5, 7. If one uses a WS-200 with only two beltpacks, use TX/RX channels 1 and 6
- b. Make sure the interface mode switch at the rear of the base station is set to "PARTY LINE".
- c. Connect the party line intercom system via the XLR-3 connectors at the rear panel of the base station. Each XLR-3 male and female pair may connect each TX/RX module to a channel of the party line intercom system (see also section 9.3.3). Everywhere this connection is made, the internal party line is interrupted.
- d. Turn down the side tone trimmers (counter clockwise).

#### 9.3.2 Wireless Beltpack Settings

- e. With the Channel Select switch at the rear of the beltpack, select the TX/RX channel according to the WS-200 or WS-400 setting.
- f. Connect a headset to the beltpack and insert fully charged batteries. When the beltpack is switched on, a single short tone should be heard and both LED's on the front panel of the unit flash for half a second. This indicates that the beltpack is functioning properly.
- g. When one pushes the CALL or TALK button, the LED's on the front panel are lit and the green LED of corresponding TX/RX module of the base station is lit. It proves the beltpack has connection with the base station.
- h. Turn down the OWN VOICE Volume trimmer at the side panel of the beltpack (counter-clockwise)
- i. Set the volume control of the beltpack at approximately 50%
- j. Push the TALK button on the beltpack, talk into the microphone and listen to your own voice (you might hear a small delay in the signal)
- k. Adjust the side tone trimmer of the referring TX/RX module in the base station so that the level of your own voice is as low as possible
- l. Adjust the OWN VOICE trimmer on the beltpack so that the level of your own voice is to your liking

#### 9.3.3 Wiring configurations when connecting to a party line intercom system

Connecting the ASL wireless system to party lines can be done in many different ways. Below three examples:

##### Example 1:

When two WS-400 base stations are installed and 8x WS-19 beltpacks are available: The drawing shows how to connect all WS-19 beltpacks to the same party line.

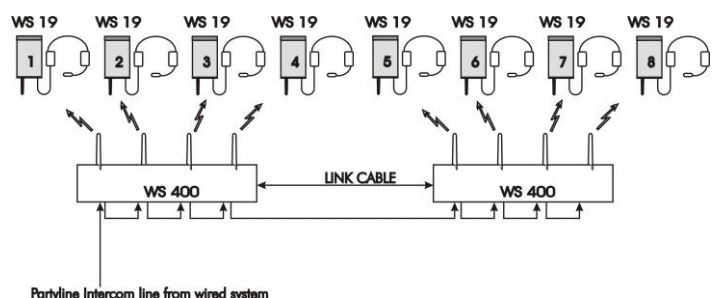

### Example 2:

When two WS-400 base stations are installed and 8x WS-19 beltpacks are available:  
The drawing shows how to connect WS-19 #1 and #2 to party line 1, WS-19 #3 and #4 to party line 2 and WS-19 #5, #6, #7 and #8 to party line 3.

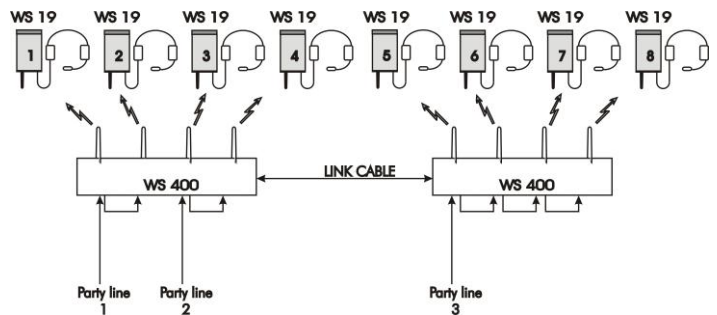

### Example 3:

When two WS-400 base stations are installed and 8x WS-29 beltpacks are available:  
The drawing shows how to connect the channels A of WS-29 #1, #2, #3 and #4 to party line 1, the channels B of WS-29 #1, #2, #3 and #4 to party line 2, the channels A of WS-29 #5, #6, #7 and #8 to party line 3 and the channels B of WS-29 #5, #6, #7 and #8 to party line 4.

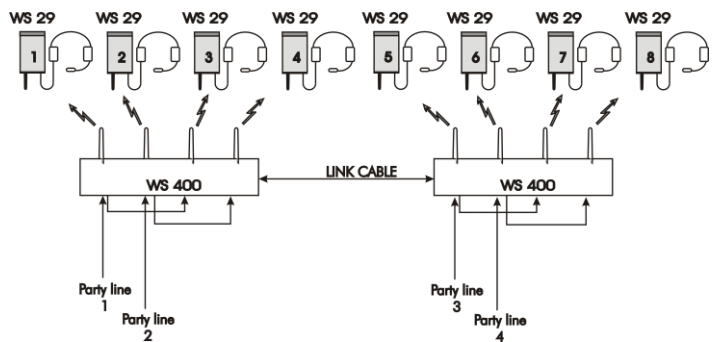

*For other examples and more information, see the WS-200 or WS-400 user manual*

## 10.0 COMMUNICATION MODES

The system is designed to offer a maximum of 8 full duplex wireless connections, simultaneously operated without any interference.

A full duplex wireless connection is accomplished by using a dedicated TX/RX channel, selected on the beltpack and on the base station. Such a TX/RX channel links the TX/RX module in a wireless beltpack to one of the TX/RX modules in the base station.

A wireless beltpack may be the WS-19 or the WS-29, both containing one TX/RX module. A base station may be the WS-200 containing two TX/RX modules, or the WS-400 containing four TX/RX modules.

When in the same space more than one base station is required, these stations have to be interconnected by WS Link Cables (an ASL accessory).

A link cable contains all signals which have to be interchanged between base stations. See the WS-200 or WS-400 user manual.

Each wireless beltpack needs to be assigned to a unique TX/RX channel. If another TX/RX module is set to the same TX/RX channel the communication is garbled and the connection does not function properly.

A TX/RX module in a base station automatically senses whether a WS-19 or a WS-29 beltpack is assigned and automatically selects the right audio routing for either beltpack type. For more information, see the WS-200 or the WS-400 user manual, section "Automatic Audio Routing".

## 11.0 WARRANTY

ASL Intercom warrants this unit to the original end-user purchaser against defects in workmanship and materials in its manufacture for a period of two years from date of shipment to the end-user.

Faults arising from misuse, unauthorized modifications or accidents are not covered by this warranty.

If the unit is faulty, it should be sent in its original packing to the supplier or your local ASL dealer, with shipping prepaid. A note must be included stating the faults found and a copy of the original suppliers invoice.

## 12.0 TECHNICAL SPECIFICATIONS

### WS-29 Power Consumption

Current (at 9 V DC):  
200 mA quiescent  
240 mA signaling  
260 mA at max. output + signaling

### Mic. Pre-amp

mic. impedance: 200 ohms  
gain: 40 dB - 70 dB  
presence filter: +6 dB at 5 kHz  
V electret mic: +4.5V DC

### Headphones Driver Amp

max. load: 200 ohms  
max. output level: 6.8 V rms @ 200  $\Omega$   
max. output power: 0.23 W rms @ 200  $\Omega$

### Buzzer

max. SPL: 65 dBA

### WS-29 Dimensions & Weight

width: 88 mm  
height: 49 mm  
depth: 141 mm  
weight: 650 grams

### System Specifications

transceiver frequency: 2400 – 2483.5 MHz  
transmit power: 10 mW E.I.R.P.  
number of channels: 8  
channel separation: 7 MHz  
dynamic range: 70 dB  
supply voltage: +7.2 V DC (4.2 V to 9 V)  
audio freq. response: 200 Hz-12 kHz (-3dB)

0 dBu is defined as 775 mV into open circuit

ASL reserves the right to alter specifications without prior notice.